

**INSTALLATION INSTRUCTIONS FOR INSTALLING A DELIVERY PAN GUARDS INSTALLATION KIT IN A NATIONAL VENDORS<sup>®</sup>, CROWN SEVENTY TWO<sup>®</sup>, SHOWCASE 141 SPIRAL SNACK MERCHANDISER**

**CHECK THE PARTS RECEIVED IN THE KIT WITH THE PARTS LIST IN THESE INSTRUCTIONS. IF ANY PARTS ARE MISSING, CONTACT NATIONAL VENDORS' PARTS DEPARTMENT IMMEDIATELY.**

These instructions cover the procedure for installing a Delivery Pan Guards Installation Kit in any Crown Seventy Two, Showcase 141 Spiral Snack Merchandiser.

Read these instructions carefully and thoroughly before installing the Kit. Retain these instructions for Part Number and Installation Information. Kit, Part Number 141-2082, contains the following parts:

Part Number	Description	Quantity
141-2077	Left Delivery Pan Guard	1
1412078	Right Delivery Pan Guard	1
9900-174	No.8-32 x 5/16 RHS T/Cutting Screw	4
141-2083	Installation Instructions * * *	1

Special Tools Required:  
 Punch or similiar pointed tool  
 Electric or Manual Hand Drill  
 9/64" Drill Bit  
 Flat File  
 Pliers or Vice Grip Pliers

**TO INSTALL THE KIT**

**A. PARTS REMOVAL**

1. Disconnect the Merchandiser Electrical Service Cord from Electrical Source.
2. Unlock and fully open the Cabinet Door to expose the Delivery Pan Assembly. See Figure 1.
3. Ensure that the Door Support Leg is in position. See Figure 1.

**B. TO INSTALL THE KIT**

**WARNING**

**Before Installing the Kit ensure that the Cabinet Door is securely Blocked.**

1. Using the Left Delivery Pan Guard Part Number 141-2077, included in the Kit, as a template locate and mark two holes in Left Hand Delivery Pan End Plate. See Figure 2.

2. Using the Right Delivery Pan Guard, Part Number 141-2078 included in the Kit, repeat Step B-1 for the Right Delivery Pan End Plate. See Figure 2.

**WARNING**

**Use Protective Glasses During Drilling Operation.**

3. Using a Electric or Manual Hand Drill with a Drill Bit, Drill two .140 Diameter Holes in the Left and Right Delivery Pan End Plates as marked in Steps B-1 and B-2. See Figure 2.
4. DeBurr Holes and remove metal shavings from Delivery Pan Assembly.
5. Position the Left Delivery Pan Guard over the newly drilled holes (Outboard side of End Plate) and install with two No.8-32 x 5/16 Round Head Thread Cutting Screws, Part Number 9900-174, included in the Kit. Tighten the two Screws. See Figure 3.
6. Repeat Step B-5 for the Right Delivery Pan Guard.

**NOTE**

*Obtain a piece of cloth or suitable material to cover the Deflector before proceeding with Step B-7.*

7. Using pliers or vice grips bend the right Sidewall Product Deflector part number 141-1063 to approximately 70° or until sufficient clearance is obtained to clear the newly installed Guard. See Figure 1.
8. Repeat Step B-7 for the left Sidewall Product Deflector part number 141-1063.
9. Open and Close the Cabinet Door several times to ensure the newly installed guards have sufficient clearance.
10. Lock the Cabinet Door.
11. Connect the Merchandiser Electrical Service Cord and Test Vend the Merchandiser.

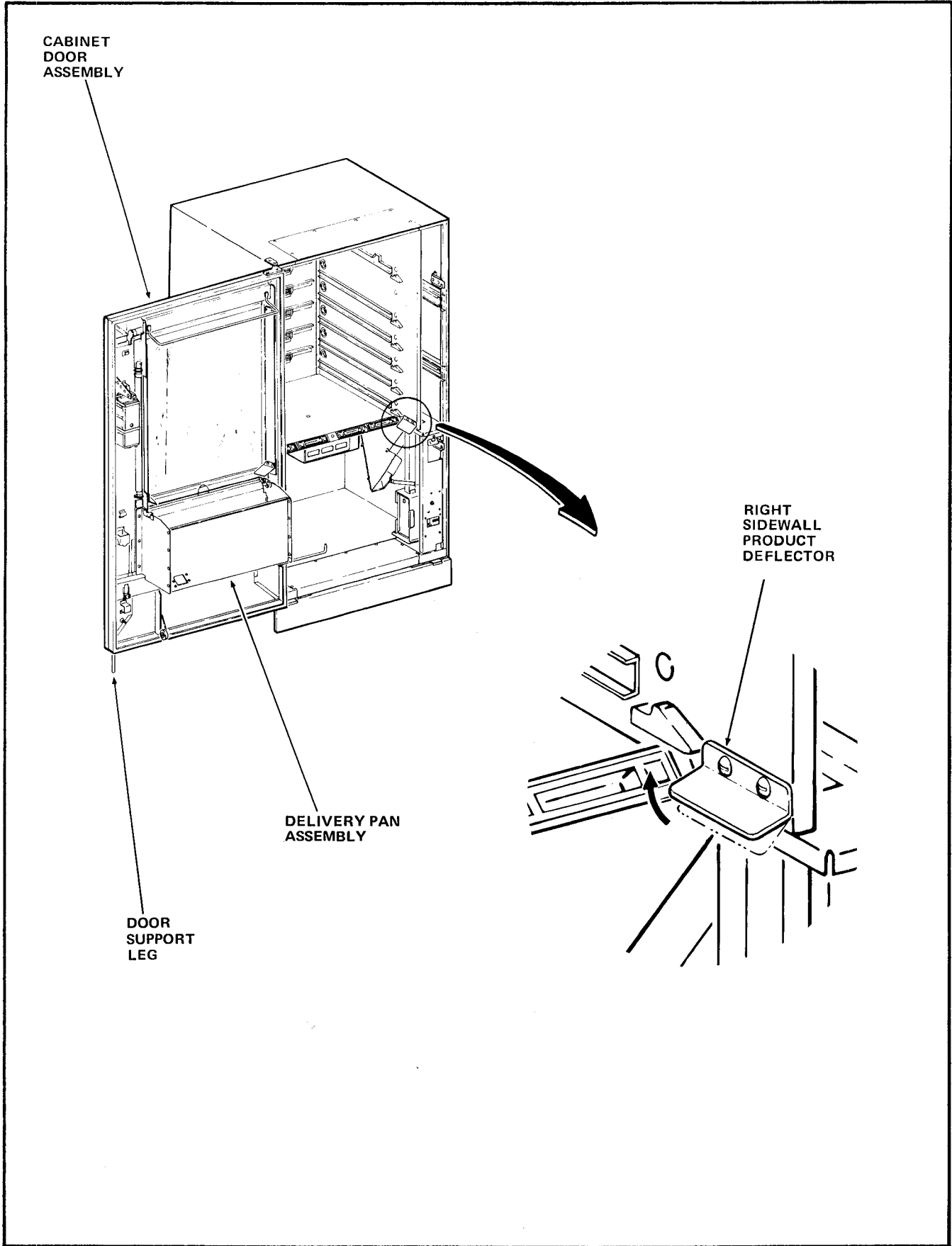

FIGURE 1

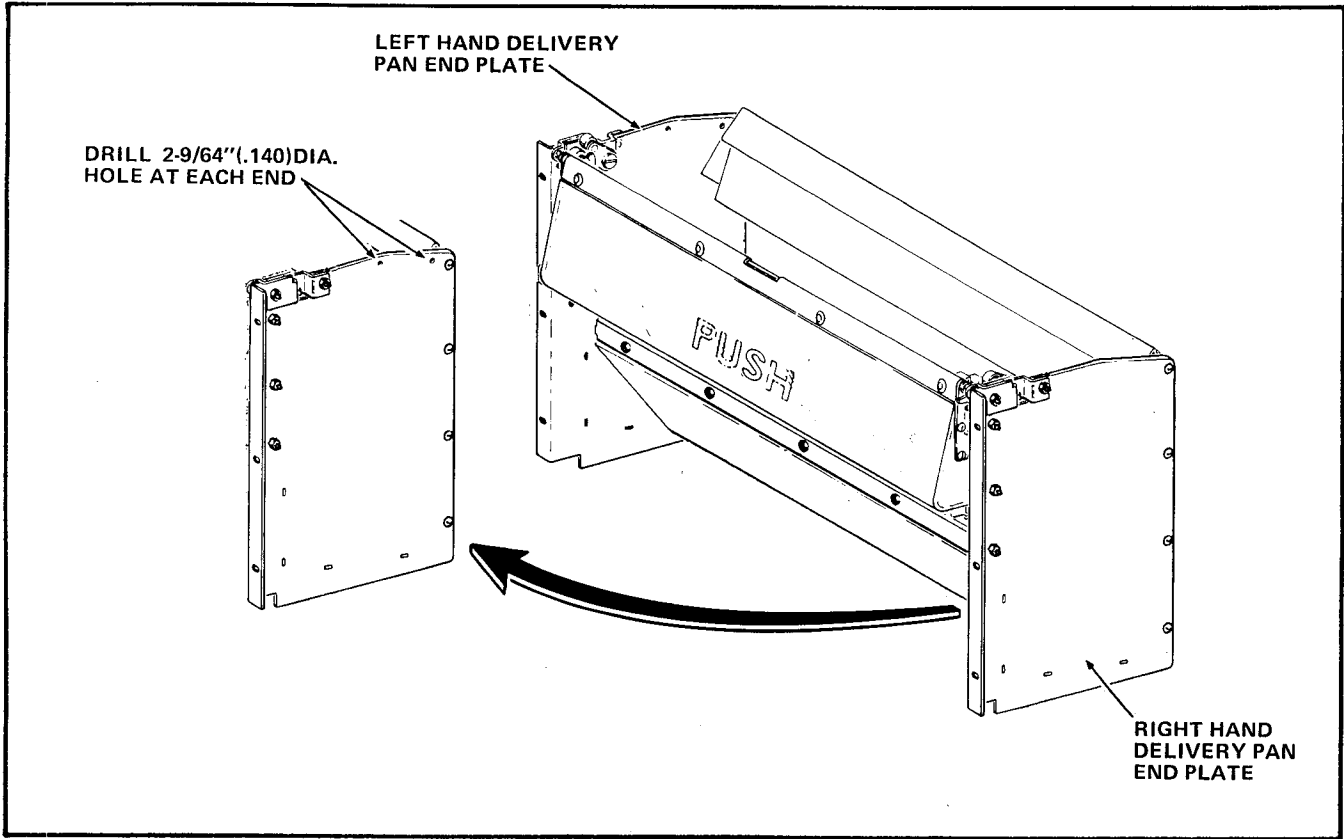

FIGURE 2

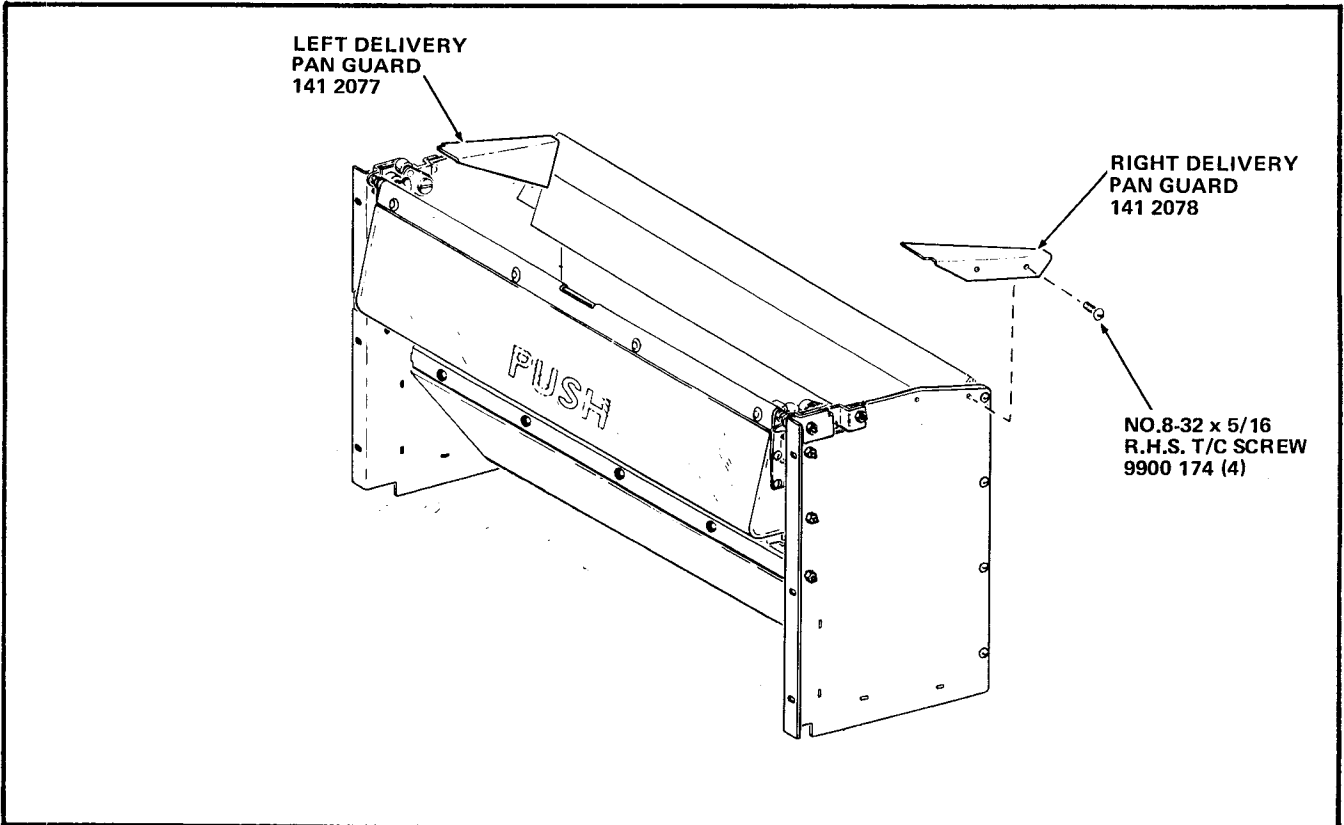

FIGURE 3